



# **Commercial Convection Gas Ranges**

*Models CE-CN-0914-RC, 0914-LC*  
*Items 47449, 47450*  
**Instruction Manual**



*Revised - 02/11/2026*

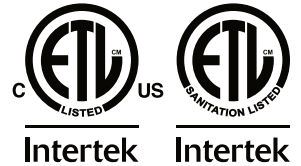

Toll Free: 1-800-465-0234  
Fax: 905-607-0234  
Email: [service@omcan.com](mailto:service@omcan.com)  
[www.omcan.com](http://www.omcan.com)



# ***Table of Contents***

Model CE-CN-0914-RC / Model CE-CN-0914-LC

---

<b>Section</b>	<b>Page</b>
General Information -----	3 - 4
Safety and Warranty -----	4 - 6
Technical Specifications -----	6
Installation -----	7 - 8
Operation -----	8 - 9
Maintenance -----	9 - 10
Troubleshooting -----	10 - 11
Parts Breakdown -----	12 - 13
Electrical Schematics -----	14
Warranty Registration -----	15



# General Information

---

Omcan Manufacturing and Distributing Company Inc., Food Machinery of America, Inc. dba Omcan and Omcan Inc. are not responsible for any harm or injury caused due to any person's improper or negligent use of this equipment. The product shall only be operated by someone over the age of 18, of sound mind, and not under the influence of any drugs or alcohol, who has been trained in the correct operation of this machine, and is wearing authorized, proper safety clothing. Any modification to the machine voids any warranty, and may cause harm to individuals using the machine or in the vicinity of the machine while in operation.

## CHECK PACKAGE UPON ARRIVAL

Upon receipt of an Omcan shipment please inspect for external damage. If no damage is evident on the external packaging, open carton to ensure all ordered items are within the box, and there is no concealed damage to the machine. If the package has suffered rough handling, bumps or damage (visible or concealed), please note it on the bill of lading before accepting the delivery and contact Omcan within 24 hours, so we may initiate a claim with the carrier. A detailed report on the extent of the damage caused to the machine must be filled out within three days, from the delivery date shown in the shipping documents. Omcan has no recourse for damaged products that were shipped collect or third party.

**Before operating any equipment, always read and familiarize yourself with all operation and safety instructions.**

Omcan would like to thank you for purchasing this machine. It's of the utmost importance to save these instructions for future reference. Also save the original box and packaging for shipping the equipment if servicing or returning of the machine is required.

---

Omcan Fabrication et distribution Compañie Limité et Food Machinery d'Amérique, dba Omcan et Omcan Inc. ne sont pas responsables de tout dommage ou blessure causé du fait que toute personne ait utilisé cet équipement de façon irrégulière. Le produit ne doit être exploité que par quelqu'un de plus de 18 ans, saine d'esprit, et pas sous l'influence d'une drogue ou d'alcool, qui a été formé pour utiliser cette machine correctement, et est vêtu de vêtements de sécurité approprié. Toute modification de la machine annule toute garantie, et peut causer un préjudice à des personnes utilisant la machine ou des personnes à proximité de la machine pendant son fonctionnement.

## VÉRIFIEZ LE COLIS DÈS RÉCEPTION

Dès réception d'une expédition d'Omcan veuillez inspecter pour dommages externes. Si aucun dommage n'est visible sur l'emballage externe, ouvrez le carton afin de s'assurer que tous les éléments commandés sont dans la boîte, et il n'y a aucun dommage dissimulé à la machine. Si le colis n'a subi aucune mauvaises manipulations, de bosses ou de dommages (visible ou cachée), notez-le sur le bond de livraison avant d'accepter la livraison et contactez Omcan dans les 24 heures qui suivent, pour que nous puissions engager une réclamation auprès du transporteur. Un rapport détaillé sur l'étendue des dommages causés à la machine doit être rempli dans un délai de trois jours, à compter de la date de livraison indiquée dans les documents d'expédition. Omcan n'a aucun droit de recours pour les produits endommagés qui ont été expédiés ou cueilli par un tiers transporteur.

# ***General Information***

---

Avant d'utiliser n'importe quel équipement, toujours lire et vous familiariser avec toutes les opérations et les consignes de sécurité.

Omcan voudrais vous remercier d'avoir choisi cette machine. Il est primordial de conserver ces instructions pour une référence ultérieure. Également conservez la boîte originale et l'emballage pour l'expédition de l'équipement si l'entretien ou le retour de la machine est nécessaire.

---

Omcan Empresa De Fabricacion Y Distribucion Inc. Y Maquinaria De Alimentos De America, Inc. dba Omcan y Omcan Inc. no son responsables de ningun daño o perjuicio causado por cualquier persona inadecuada o el uso descuidado de este equipo. El producto solo podra ser operado por una persona mayor de 18 años, en su sano juicio y no bajo alguna influencia de droga o alcohol, y que este ha sido entrenado en el correcto funcionamiento de esta máquina, y ésta usando ropa apropiada y autorizada. Cualquier modificación a la máquina anula la garantía y puede causar daños a las personas usando la máquina mientras esta en el funcionamiento.

## **REVISE EL PAQUETE A SU LLEGADA**

Tras la recepcion de un envio Omcan favor inspeccionar daños externos. Si no hay daños evidentes en el empaque exterior, Habra el carton para asegurarse que todos los articulos solicitados estén dentro de la caja y no encuentre daños ocultos en la máquina. Si el paquete ha sufrido un manejo de poco cuidado, golpes o daños (visible o oculto) por favor anote en la factura antes de aceptar la entrega y contacte Omcan dentro de las 24 horas, de modo que podamos iniciar una reclamación con la compañía. Un informe detallado sobre los daños causados a la máquina debe ser llenado en el plazo de tres días, desde la fecha de entrega que se muestra en los documentos de envío. Omcan no tiene ningun recurso por productos dañados que se enviaron a recoger por terceros.

Antes de utilizar cualquier equipo, siempre lea y familiarizarse con todas las instrucciones de funcionamiento y seguridad.

Omcan le gustaría darle las gracias por la compra de esta máquina. Es de la mayor importancia para salvar estas instrucciones para futuras consultas. Además, guarda la caja original y el embalaje para el envío del equipo si servicio técnico o devolución de la máquina que se requiere.

# ***Safety and Warranty***

---

This manual contains important information regarding your purchased equipment. Please read the manual thoroughly prior to equipment set-up, operation and maintenance. Failure to comply with regular maintenance guidelines outlined in this manual may void the warranty. Please keep it for future reference after installation and do not throw it away! This is a universal installation and operation instruction book which would apply to different models. PLEASE READ!!!



# Safety and Warranty

---

**IMPORTANT FOR YOUR SAFETY: THIS MANUAL HAS BEEN PREPARED FOR PERSONNEL QUALIFIED TO INSTALL GAS EQUIPMENT, WHO SHOULD PERFORM THE INITIAL FIELD START-UP AND ADJUSTMENTS OF THE EQUIPMENT AS COVERED BY THIS MANUAL.**

**IMPORTANT: IN THE EVENT A GAS ODOR IS DETECTED, SHUT DOWN UNITS AT MAIN SHUTOFF VALVE AND CONTACT THE LOCAL GAS COMPANY OR GAS SUPPLIER FOR SERVICE.**

**FOR YOUR SAFETY: DO NOT STORE OR USE GASOLINE OR OTHER FLAMMABLE VAPORS OR LIQUIDS IN THE VICINITY OF THIS OR ANY OTHER APPLIANCE.**

**WARNING: IMPROPER INSTALLATION, ADJUSTMENT, ALTERATION, SERVICE OR MAINTENANCE CAN CAUSE PROPERTY DAMAGE, INJURY OR DEATH. READ THE INSTALLATION, OPERATING AND MAINTENANCE INSTRUCTIONS THOROUGHLY BEFORE INSTALLING OR SERVICING THIS EQUIPMENT.**

**IN THE EVENT OF A POWER FAILURE, DO NOT ATTEMPT TO OPERATE THIS DEVICE.**

## WARNINGS

- Do not touch any hot surfaces.
- Do not use this unit for any other than intended use.
- Do not use outdoors.
- Always use on a firm, dry and level surface.
- Keep the appliance area free and clear from combustibles.
- The manual shall be retained for future reference.
- Do not store or use gasoline or other flammable vapors or liquids in the vicinity of this or any other equipment.
- Improper installation, adjustment, alteration, service or maintenance can cause property damage, injury or death.
- Read the installation and maintenance instructions thoroughly before installing or servicing this equipment.
- Have the equipment installed by a qualified installer in accordance with all federal, state and local codes.
- Do not install or use without all 4 legs.
- This equipment is for use in non-combustible locations only.
- Do not obstruct the flow of combustion and ventilation air.
- Do not spray controls or the outside of the equipment with liquids or cleaning agents.
- Allow for hot parts to cool before cleaning or moving.
- This equipment should only be used in a flat, level position.
- Do not operate unattended.
- Any loose dirt or metal particles that are allowed to enter the gas lines on this equipment will damage the valve and affect its operation.
- If you smell gas, follow the instructions provided by the gas supplier. Do not touch any electrical switch; do not try to light the burner; do not use a telephone within close proximity.
- Never attempt to move grates while cooking.

**RESIDENTIAL USERS: Vendor assumes no liability for parts or labor coverage for component failure or**

# Safety and Warranty

other damages resulting from installation in non-commercial or residential applications. The right is reserved to deny shipment for residential usage; if this occurs, you will be notified as soon as possible.

## 1 YEAR PARTS AND LABOUR WARRANTY

Within the warranty period, contact Omcan Inc. at 1-800-465-0234 to schedule an Omcan authorized service technician to repair the equipment locally.

Unauthorized maintenance will void the warranty. Warranty covers electrical and part failures, not improper use.

Please see <https://omcan.com/disclaimer> for complete info.

### WARNING:

The packaging components are classified as normal solid urban waste and can therefore be disposed of without difficulty.

In any case, for suitable recycling, we suggest disposing of the products separately (differentiated waste) according to the current norms.

**DO NOT DISCARD ANY PACKAGING MATERIALS IN THE ENVIRONMENT!**

# Technical Specifications

Model	CE-CN-0914-RC	CE-CN-0914-LC
Gas Type	Natural Gas	Liquid Propane
Number of Burners	6	
Total Input BTU Per Hour	211,000 BTU	
Electrical	110-120V / 60Hz	
Current	1.5A	
Oven Temperature	105 - 255°C / 220 - 490°F	
Oven Dimensions	26.6" x 23.8" x 13.9" / 676 x 605 x 353mm	
Dimensions	36" x 35" x 56.5" / 915 x 889 x 1435mm	
Shipping Dimensions	41" x 38" x 35" / 1040 x 1010 x 890mm	
Weight	386 lbs. / 175 kgs.	
Packaging Weight	485 lbs. / 220 kgs.	
Item Number	47449	47450

## BEFORE INSTALLATION

- Installation of this device should be performed by professional technicians.
- Installation of this unit should conform to provisions of gas safety, installation and usage.
- Check that electrical (if needed) and gas supply agree with the specifications on the rating plate located inside the kick panel of the unit. If the supply and equipment requirements do not agree, do not proceed with the installation. Contact your dealer immediately.
- Unit must be installed so that the flow of combustion and ventilation air will not be obstructed, ensure that there is an adequate supply of air in the room to allow proper combustion of gas at the burners.
- This device should be kept a minimum clearance of 12" from combustible construction at the sides and 10" at the rear. Clearance from non-combustible construction is 6" sides and 6" at the back. Do not install on a flammable floor or around other combustible objects.
- This item is intended to sit on a solid and level floor.

## INSTALLATION

- The installation of this equipment must conform with local codes, or with the National Gas Code, ANSI Z223.1/NFPA 54, or the Natural Gas and Propane Installation Code, CSA B149.1, as applicable.
- The equipment and its individual shutoff valve must be disconnected from the gas supply piping system during any pressure testing of that system at test pressures in excess of ½ psi (3.5 kPa).
- The equipment must be isolated from the gas supply piping system by closing its individual manual shutoff valve during any pressure testing of the gas supply piping system at test pressures equal to or less than ½ psi (3.5 kPa).

## CLEARANCE AND POSITIONING AROUND THE EQUIPMENT

- This equipment must be installed adjacent to non-combustible surfaces only with a minimum spacing of 6" from all sides. This equipment must be a distance of 6" from other equipment. The equipment must have the 4" legs installed and be placed on a non-combustible surface.
- For an oven equipped with casters, the installation shall be made with a connector that complies with the Standard for Connectors for Movable Gas Appliances, ANSI Z21.69/CSA 6.16 and a quick-disconnect device that complies with the Standard for Quick-Disconnect Devices for Use with Gas Fuel, ANSI Z21.4/CSA 6.9. When installing the oven with casters and quick-disconnect hose, adequate means must be provided to limit the movement of the oven without depending on the connector and the quick disconnect device or its associated piping to limit the oven movement. Restraining means may be attached to the vertical portion of the base frame in the rear of the oven.

## AIR SUPPLY AND VENTILATION

- The area in front and around the equipment must be kept clear to avoid any obstruction of the flow of combustion and ventilation air.
- Adequate clearance must be maintained at all times in front of and at the sides of the equipment for servicing and proper ventilation.

# Installation

---

## TO INSTALL

1. Level the device with a level gauge. The height can be adjusted by the adjustable feet. Unit should not sway or tilt during operation. Units that are not level will experience operational problems.
2. The mounting position should be well-ventilated with proper hood exhaust system.
3. Codes require that a gas shut off valve should be installed upstream the device where it is easily reached during operation.
4. Make sure you are using the correct gas supply that is specified for this model. If the gas supply is not intended for this model, do not proceed with installation.
5. This unit is applicable to low pressure regulating valves only. High pressure regulating valves and medium pressure regulating valves are not to be used.
6. Check to make sure the connection pipe to the unit has no leaks and that all connections and pipe joint compound used are resistant to the action of propane gases.
7. A pressure regulator must be installed with this unit. Ensure that the regulator type is in agreement with the rating plate gas supply. Regulator must be upright after installation. If regulator is not level during operation, performance problems may result.
8. After connecting the appliance to the gas system, check for leaks at joints and pipe fittings; to do so, use soapy water or a specific leak detector (spray).
9. Check the gas supply pressure after installation.
10. Gas supply pressure can be measured with a liquid-filled pressure gauge (e.g. a U shaped pressure gauge, minimum scale division 0.1mbar) or a digital gauge. Procedure as follows:
  - Ensure gas is turned off.
  - Remove the panel and unscrew the screw on the pressure port.
  - Place the pressure gauge.
  - Start up the appliance by following the instructions in this owner's manual.
  - Check supply pressure. Pressure must agree with rating plate requirement when the unit is in full operation.
  - After the check, turn off gas and remove the pressure gauge.
  - Replace the sealing screw.

# Operation

---

When turning on for the first time please be advised that it might take a little longer to ignite due to the air existing in the pipe.

## BURNERS

- Turn on the gas supply and ignite the pilot flame with a lighter. If the unit hasn't been used in a while or if this is the first lighting, ignition might take a little longer (about two or three minutes).
- Press the corresponding valve knob of burner and turn 90 degrees counterclockwise. The burner will be ignited and the flame will be at Max. To set the flame to Min, rotate counterclockwise another 90 degrees.
- When finished turn off main burner by rotating the knob clockwise to off position. Pilot should remain lit.

# Operation

- For complete shutdown, ensure that all burner knobs are turned to the off position, and then turn main gas supply off.

## CONVECTION OVEN

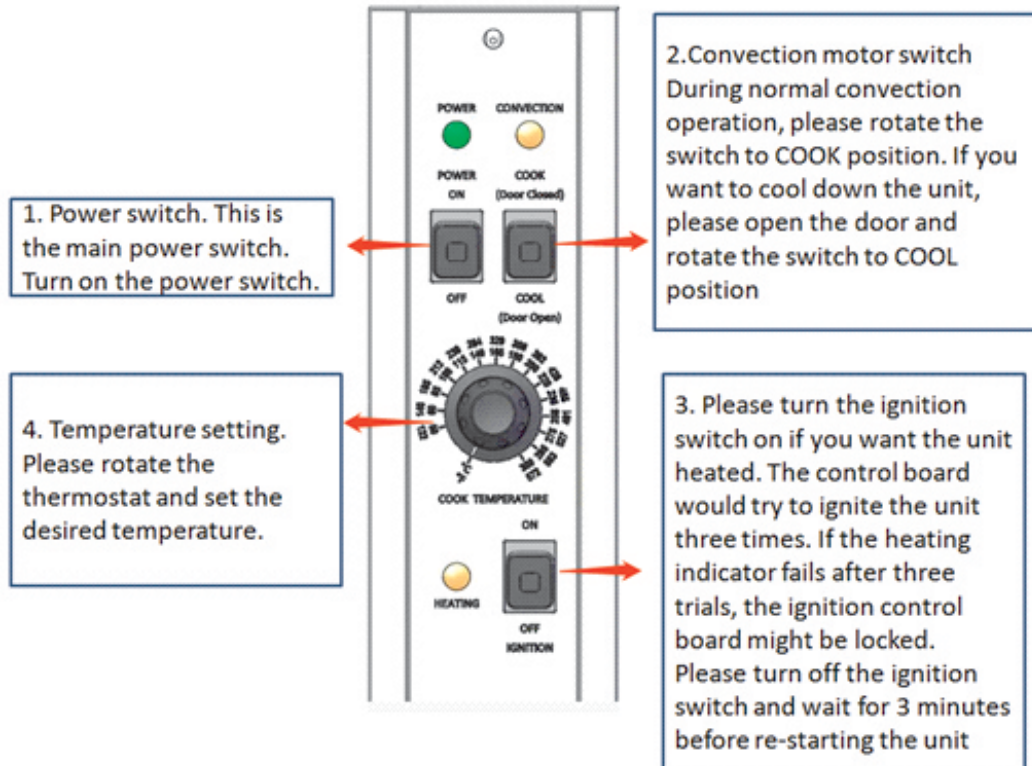

# Maintenance

## GAS CONVERSION

Conversion from Natural Gas to Liquid Propane (LP) or vice versa may only be performed by the factory or its authorized service agent.

## CLEANING

**NOTE:** It is important to check the machine daily. Checking the machine regularly can avoid serious accidents. Stop using if user feels that there are some problems with the unit. Check the condition of the machine before and after using every day.

1. Before cleaning, turn off all gas valves.

# Maintenance

---

2. Please clean the burners and drip tray of all debris and spillage daily. A complete cleaning every day will ensure a good service and extend the service life of the unit.
3. Clean the stainless steel surface with warm soapy water every day and rinse it completely. Do not saturate range with water, excessive water will cause operational issues. During cleaning, do not clean the stainless steel surface with abrasive detergent, brush or scraper etc. The residual iron scale may cause rusting.
4. Do not clean the surface with chlorine cleanser (bleach, dish detergent, hydrochloric acid etc.). Do not clean the floor where the device locates with corrosive substance.
5. Do not change the burner shutter settings.
6. Accumulation of substances containing salt or acidic ingredients, e.g. vinegar, lemon juice, spices, salt etc. can cause corrosion. Thus, please do not allow these substances to have long contact with the unit.
7. After cleaning, ensure that the ports of the burners are open and clear of any residue.
8. Clean cast iron top grates with a mild soap and water solution. Rinse thoroughly and dry with a clean, water-absorbent towel. Immediately after drying, season grates lightly with liquid vegetable oil. After seasoning, replace grates on range and turn burners on LOW, allow grates to heat for 15 minutes before using pots or pans on the range top. Failure to season grates after cleaning will result in rust.
9. If unit will sit idle for a significant period of time, please turn off the gas valve upstream the device.

# Troubleshooting

---

Problem	Possible Causes	Solutions
The pilot flame can't be ignited.	The gas pressure is too low.	Adjust the relieve valve to increase pressure.
	The nozzle is clogged.	Unclog the nozzle.
	Connection of the thermocouple is loose.	Tighten the thermocouple.
	The thermocouple is defective.	Replace the thermocouple.
	The gas control valve is malfunctioning.	Replace the gas control valve.
The pilot flame is on but the main burner can't be ignited.	The gas pressure is too low.	Adjust the relieve valve to increase pressure.
	The main burner nozzle is clogged.	Unclog the nozzle.
	The gas control valve is defective.	Replace the gas control valve.
It has a light back sound when the gas supply is turned off.	Wrong orifice size for the gas supply.	Install proper orifice.
	The air shutter is too open.	Adjust the damper.
	Gas pressure too low.	Increase the gas pressure.

# Troubleshooting

<b>Problem</b>	<b>Possible Causes</b>	<b>Solutions</b>
It has a yellow flame and black smoke.	Wrong orifice size for the gas supply.	Install proper orifice.
	The air shutter is closed too far.	Adjust the air shutter.
	Running out of gas/propane.	Replace tank/ increase gas.
	High elevation.	Install proper orifices for elevation.
	Bad air/gas mixture.	Increase air flow/gas to the unit.

# Parts Breakdown

**Model CE-CN-0914-RC** 47449

**Model CE-CN-0914-LC** 47450

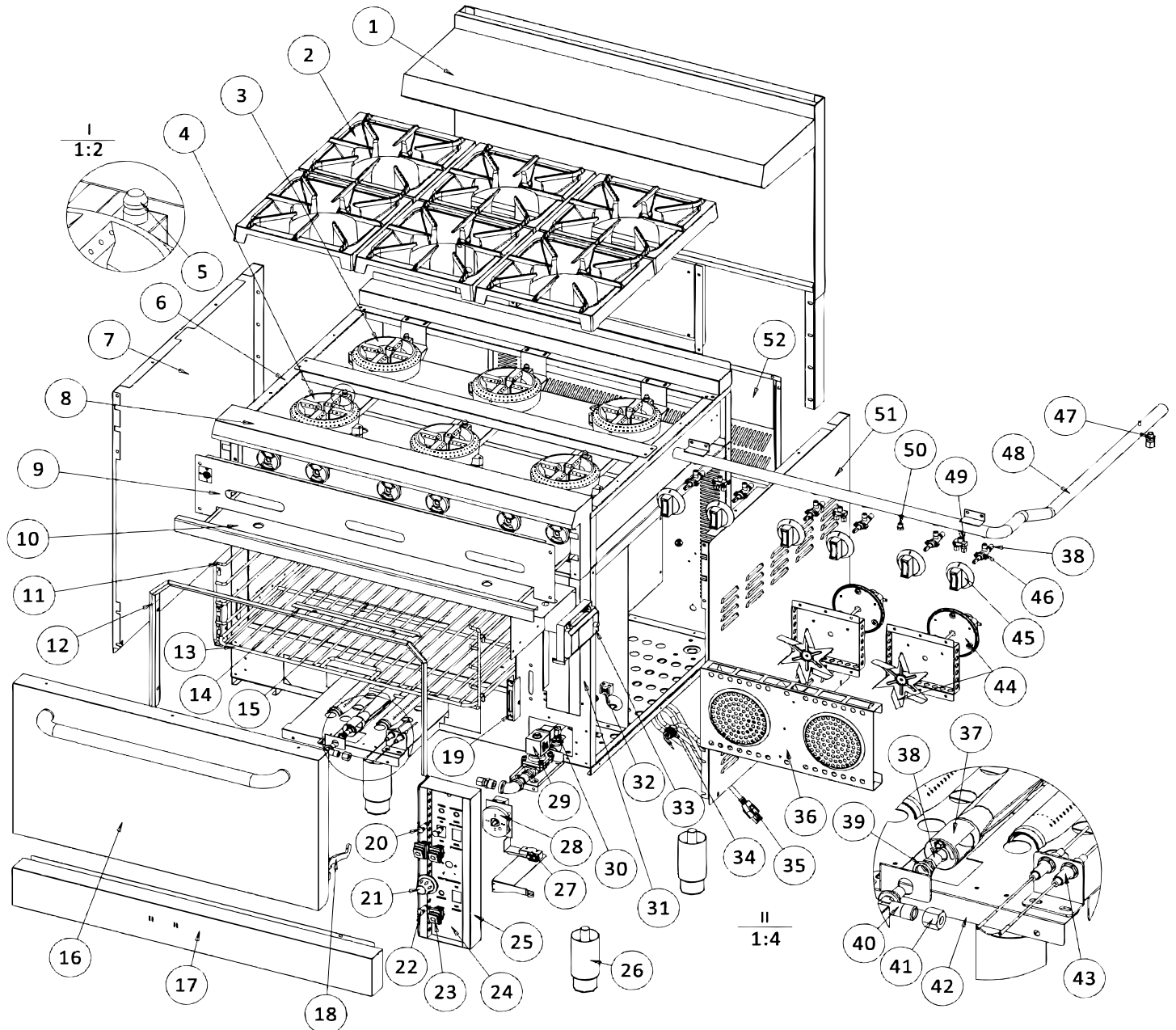



# Parts Breakdown

**Model CE-CN-0914-RC 47449**

**Model CE-CN-0914-LC 47450**

Item No.	Description	Position	Item No.	Description	Position	Item No.	Description	Position
AJ571	Top Burner Grate for 47449, 47450	2	AJ583	Fascia Panel for 47449, 47450	24	AJ595	Oven Nozzle for 47449, 47450	38
AJ572	Long Burner Assembly for 47449, 47450	3	AJ584	Stainless Steel Adjustable Leg for 47449, 47450	26	AJ596	Flat Nut for 47449, 47450	39
AJ573	Short Burner Assembly for 47449, 47450	4	AH179	Swivel Caster for 47449, 47450	26a	AJ597	Nozzle Connecting Elbow for 47449, 47450	40
AJ574	Pilot for 47449, 47450	5	AJ585	Travel Switch for 47449, 47450	27	AJ598	Elbow Nut for 47449, 47450	41
AJ575	Oven Baking Grid Shelf for 47449, 47450	11	AJ586	Oven Digital Thermostat for 47449, 47450	28	AJ599	Electrode for 47449, 47450	43
AJ576	Oven Baking Grid for 47449, 47450	13	AJ587	Solenoid Valve for 47449, 47450	29	AJ600	Motor Assembly for 47449, 47450	44
AJ577	Thermostat Sensor for 47449, 47450	15	AJ588	1/2-10 Pipe Connector for 47449, 47450	30	AJ601	Top Burner Knob for 47449, 47450	45
AJ578	Oven Door Hinge (Insert to the Door) for 47449, 47450	18	AJ589	Terminal Block for 47449, 47450	32	AJ602	Top Burner Control Valve for 47449, 47450	46
AJ579	Oven Door Hinge Bracket for 47449, 47450	19	AJ590	Ignitor for 47449, 47450	33	AJ603	1/4-10 Pipe Connector for 47449, 47450	47
AJ580	Oven Power Indicator for 47449, 47450	20	AJ591	Power Cord Sheath for 47449, 47450	34	AJ604	Pilot Valve for 47449, 47450	49
AJ581	Oven Thermostat Valve Knob for 47449, 47450	21	AJ592	Power Cord for 47449, 47450	35	AJ605	Test Plug for 47449, 47450	50
AD711	Working Indicator for 47449, 47450	22	AJ593	Air Deflector Assembly for 47449, 47450	36			
AJ582	Power Switch for 47449, 47450	23	AJ594	Oven Burner for 47449, 47450	37			

# Electrical Schematics

**Model CE-CN-0914-RC** 47449

**Model CE-CN-0914-LC** 47450

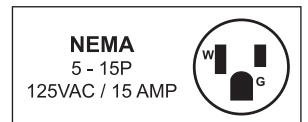
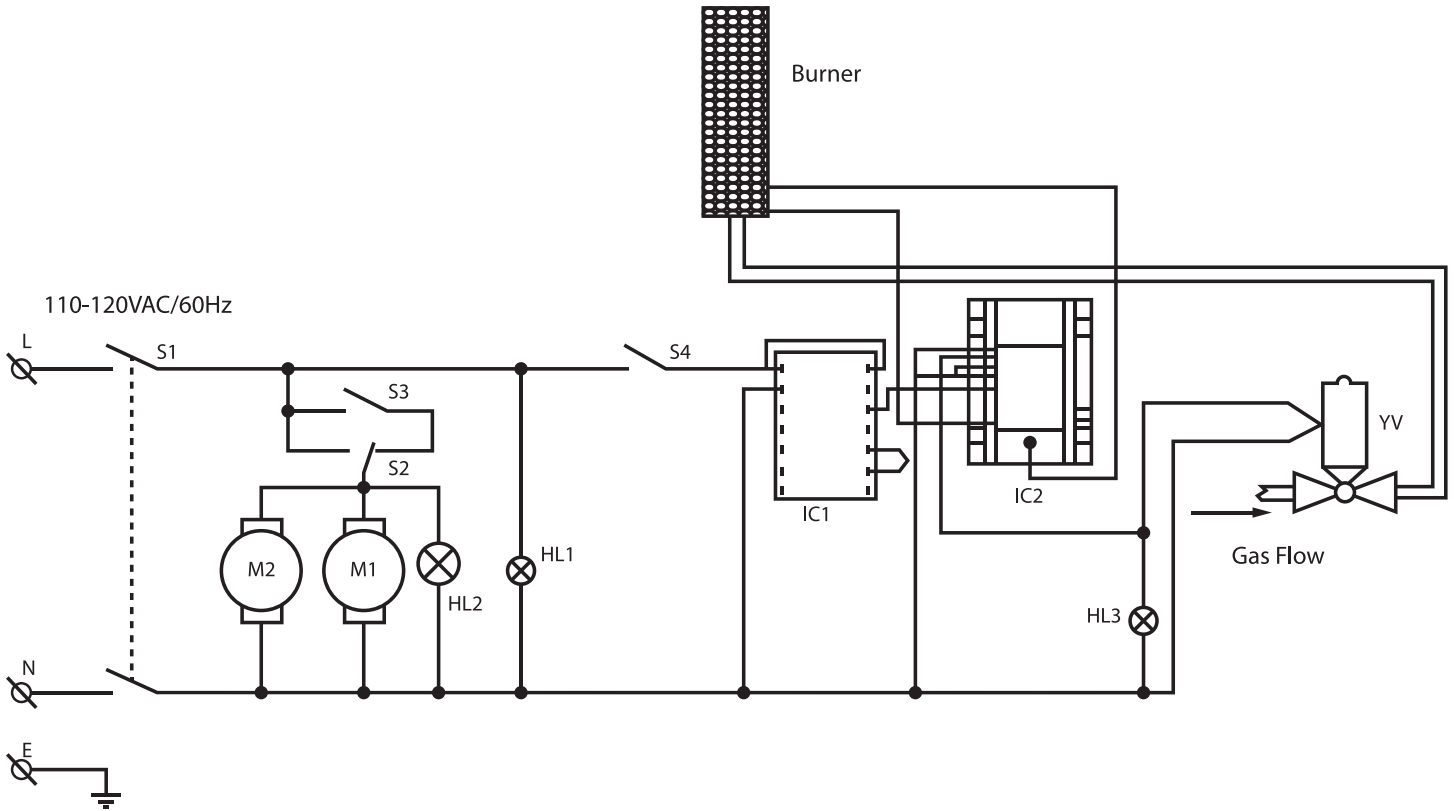

Code	Description
HL1	Power Indicator
HL2	Motor Indicator
HL3	Ignition Indicator
IC1	Digital Thermostat

Code	Description
IC2	Ignition Module
M1/M2	Motor
S1	Power On/Off Switch
S2	Cook/Cool Switch

Code	Description
S3	Micro Switch
S4	Gas Ignition Switch
YV	Solenoid Valve



# Warranty Registration

Thank you for purchasing an Omcan product. To register your warranty for this product, complete the information below, tear off the card at the perforation and then send to the address specified below. You can also register online by visiting:

Merci d'avoir acheté un produit Omcan. Pour enregistrer votre garantie pour ce produit, complétez les informations ci-dessous, détachez la carte au niveau de la perforation, puis l'envoyer à l'adresse spécifiée ci-dessous. Vous pouvez également vous inscrire en ligne en visitant:

Gracias por comprar un producto Omcan usted. Para registrar su garantía para este producto, complete la información a continuación, cortar la tarjeta en la perforación y luego enviarlo a la dirección indicada a continuación. También puede registrarse en línea en:

<https://omcan.com/warranty-registration/>

**For mailing in Canada**  
**Pour postale au Canada**  
**Por correo en Canadá**

**For mailing in the US**  
**Pour diffusion aux États-Unis**  
**Por correo en los EE.UU.**

**OMCAN**  
PRODUCT WARRANTY REGISTRATION  
3115 Pepper Mill Court,  
Mississauga, Ontario  
Canada, L5L 4X5

**OMCAN**  
PRODUCT WARRANTY REGISTRATION  
4450 Witmer Industrial Estates, Unit 4,  
Niagara Falls, New York  
USA, 14305

*or email to: [service@omcan.com](mailto:service@omcan.com)*



#### Purchaser's Information

Name: \_\_\_\_\_

Address: \_\_\_\_\_

City: \_\_\_\_\_ Province or State: \_\_\_\_\_ Postal or Zip: \_\_\_\_\_

Country: \_\_\_\_\_

Dealer from which Purchased: \_\_\_\_\_

Dealer City: \_\_\_\_\_ Dealer Province or State: \_\_\_\_\_

Invoice: \_\_\_\_\_

Model Name: \_\_\_\_\_ Model Number: \_\_\_\_\_

Machine Description: \_\_\_\_\_

Date of Purchase (MM/DD/YYYY): \_\_\_\_\_

Would you like to extend the warranty?  Yes  No

Company Name: \_\_\_\_\_

Telephone: \_\_\_\_\_

Email Address: \_\_\_\_\_

Type of Company:

- Restaurant     Bakery     Deli  
 Butcher     Supermarket     Caterer  
 Institution (*specify*): \_\_\_\_\_  
 Other (*specify*): \_\_\_\_\_

Serial Number: \_\_\_\_\_

Date of Installation (MM/DD/YYYY): \_\_\_\_\_

**Thank you for choosing Omcan | Merci d'avoir choisi Omcan | Gracias por elegir Omcan**



Since 1951 Omcan has grown to become a leading distributor of equipment and supplies to the North American food service industry. Our success over these many years can be attributed to our commitment to strengthen and develop new and existing relationships with our valued customers and manufacturers. Today with partners in North America, Europe, Asia and South America, we continually work to improve and grow the company. We strive to offer customers exceptional value through our qualified local sales and service representatives who provide convenient access to over 6,500 globally sourced products.

---

Depuis 1951 Omcan a grandi pour devenir un des “leaders” de la distribution des équipements et matériel pour l’industrie des services alimentaires en Amérique du Nord. Notre succès au cours de ces nombreuses années peut être attribué à notre engagement à renforcer et à développer de nouvelles et existantes relations avec nos clients et les fabricants de valeur. Aujourd’hui avec des partenaires en Amérique du Nord, Europe, Asie et Amérique du Sud, nous travaillons continuellement à améliorer et développer l’entreprise. Nous nous efforçons d’offrir à nos clients une valeur exceptionnelle grâce à nos ventes locales qualifiées et des représentants de service qui offrent un accès facile à plus de 6500 produits provenant du monde entier.

---

Desde 1951 Omcan ha crecido hasta convertirse en un líder en la distribución de equipos y suministros de alimentos en América del Norte industria de servicios. Nuestro éxito en estos años se puede atribuir a nuestro compromiso de fortalecer y desarrollar nuevas relaciones existentes con nuestros valiosos clientes y fabricantes. Hoy con socios de América del Norte, Europa, Asia y América del Sur, que trabajan continuamente para mejorar y crecer la empresa. Nos esforzamos por ofrecer a nuestros clientes valor excepcional a través de nuestro local de ventas y representantes de los servicios que proporcionan un fácil acceso a más de 6,500 productos con origen a nivel mundial.

